



November 2, 2023

TO: Salt Lake City Planning Commission  
Salt Lake City Landmark's Commission

FROM: Judi Short, Vice Chair and Land Use Chair  
Sugar House Community Council

RE: PLNPCM2023-00444 Text Amendment Related to Window Requirements for New Construction in the City's  
Local Historic Districts

This petition was discussed at the August 21 meeting of the SHCC Land Use Committee.

Please read the attached brochure about Vinyl windows. There are many negative reasons why these are a bad idea. The manufacture of polyvinyl chloride (PVC) is one of the most toxic production processes there is.

We need to be clear that this ordinance to prohibit vinyl windows is only for new construction. We feel that vinyl windows should not be used if the window is visible from the street. And a hybrid approach seems to be reasonable, and it is too bad if that takes more staff time. We want our wonderful neighborhoods to remain, and not start to look tacky because cheap materials are being used. We have enough of that in the rest of our city, we don't need it in our historic districts. We realize that the cost of a wooden window is more than a vinyl window, but maybe the fact that they will last forever will tip the scale? My house is 125 years old, the guy who "restored" the home to a livable condition in the 1970s, before I purchased the house, took out the wooden windows, and replaced them with very cheap single pane aluminum windows that didn't keep a bit of warmth in the house. The vinyl windows I put in thirty+ years ago made a big difference in terms of heat loss, as did the foam insulation in all the walls. I would have put in wooden replacements if I had the money. And the vinyl windows are still in perfect condition.

We think that a hybrid approach to this is the right thing to do. Each project needs to be reviewed separately, to ensure that the end result will be satisfactory. The new construction needs to fit into the "old" neighborhood.

I have attached a couple of comments from the committee.

Enclosure:

Comments – Windows in Historic Neighborhoods

## COMMENTS – Windows in Historic Neighborhoods from SHCC

The Window petition is to allow more flexibility in building materials in new construction on non-primary visualized surfaces. I agree the petition is poorly worded and needs more clarity. I do suggest moderation for limiting building material types as manufacturing is always changing and improving and if you allow aluminum clad wood, often painted, why not other types of cladding. The primary structure and design are more important than individual windows off main sight lines.

Heidi Schubert 831 Coatsville Ave

I don't think that vinyl windows would be appropriate for new (or old) construction in an historic area. First, and I know because I have some) they are ugly and they are not environmentally friendly (they are made from refined oil and theoretically will take around 1000 years to decompose!). They only last about 20 years (less if exposed to extreme temps and full sun for long periods), the wood windows I have are over 100 years old and still holding. I understand it's more expensive, but if you are building in a historic district then you should be required to build something that fits into the historic area and should be around long enough to actually become "historic". Yvonne Martinez

Lynn Schwarz

Vinyl windows are not appropriate for use under any circumstances in local historic districts. They look cheap and they don't last. There are viable substitutes readily available in the marketplace.

## Why Say "No" to Vinyl Windows?

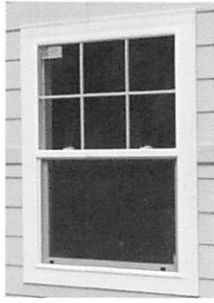

Since vinyl windows became available in the mid-1980s, property owners have seen them as an inexpensive and maintenance-free way of replacing their tired, old wood windows. "Eliminate all drafts!" — "Save on your heating bill!!!" — "Make your house look like new!!!" — Why would anyone say "no?"

The first thing to remember is that a vinyl window salesperson is selling vinyl windows. They are not going to tell you that your windows can be repaired — he or she needs to sell you new windows to stay in business. The sales pitch is not going to include any of the drawbacks to vinyl windows, only the pluses.

Second, there is no such thing as a maintenance-free house. Here are some reasons why not to replace your wood windows with vinyl:

► Vinyl windows are not going to solve your energy problems. There have been many studies on the energy efficiency of wood and vinyl windows. Based on an exhaustive 1996 study in Vermont, a "tight" wood window (meaning it doesn't rattle and is weather-stripped) with a storm window will be as energy efficient as a vinyl thermo-pane window.

► Windows account for about 20% of a home's heat loss. Insulating your attic is a far better use of your money. Multiple layers of glass (i.e., thermo-pane windows) are a small part of the heat loss equation. Only a small percentage of a single-pane window's heat loss is through the glass itself. Air infiltration around a window accounts for the remainder, so tighten up those windows and plug the gaps.

► If you have wood windows, chances are they've been there 100, or even 150 years. Why mess with success? If you do install vinyl windows, you'll often get a "life-time" guarantee. Often the company that made them will no longer be around to honor that guarantee. All windows expand and contract with temperature changes; however, vinyl expands more than twice as much as wood and seven times more than glass. Their seals will eventually fail, the desiccant will evaporate, and the windows will fog. The window may last for life, but its practical life will be much shorter.

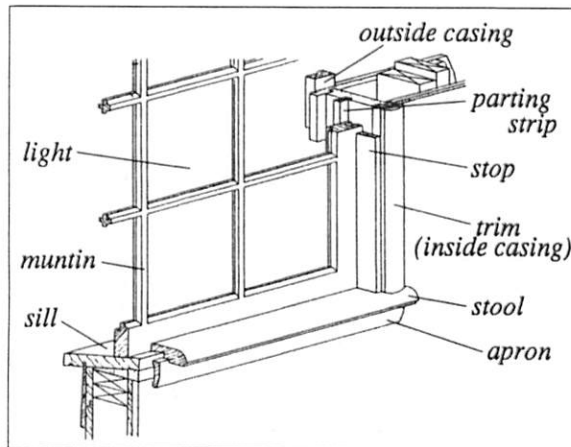

► The energy savings realized by replacing single-pane windows with vinyl windows seldom justifies the replacement cost. Have the Energy Trust of Oregon ([www.energytrust.org](http://www.energytrust.org)) do a free energy audit on your house and see how many pennies you can save a month by replacing all your windows. It can easily take *decades* to recover replacement costs and with an average life of 25 years or less, vinyl windows hardly make good economic sense.

► In a historic neighborhood, if there are seven houses on a block with original wood windows and the eighth house has vinyl windows, the value of the house with vinyl windows is going to suffer. People pay for integrity in historic districts. Original wood windows are important architectural features in any historic building. They show craftsmanship and detail that cannot be achieved in vinyl.

► Wood windows are sustainable. Your wood windows have already been created. The energy to produce them has already been expended. They are made of materials natural to the environment and are renewable. Vinyl windows are created through a toxic petroleum manufacturing process, are unrepairable, and are harmful to the environment when they are inevitably thrown away.

► The manufacture of polyvinyl chloride (PVC), is one of the most toxic production processes there is. Dioxin is formed when PVC is manufactured and when it is burned. Dioxin is a carcinogen and among the most toxic chemicals known. Firefighting has become a serious problem at vinyl-encased homes. Fortunately, the windows are not toxic while they are being used, but they are toxic to produce and toxic to dispose of.

### Additional Information

For more information concerning window restoration or any topic dealing with historic building ownership, please contact Albany's Historic Preservation program through the Planning Department.

For online readers, the best source for repairing historic wood windows is National Park Service Brief #9 available at [www.cr.nps.gov/hps/tps/briefs/brief09.htm](http://www.cr.nps.gov/hps/tps/briefs/brief09.htm).

*Working Windows* by Terry Meany is the best book available concerning the maintenance and restoration of wood windows and on making them energy efficient. *The Old-House Journal Compendium* has a terrific section on historic window repair. As the title says, it's a compendium of sage advice and instruction from years of *Old-House Journal* articles.



## ***Albany's Landmark Advisory Commission***

The Albany Landmarks Advisory Commission (LAC) was established by the City Council in 1979. The seven-member commission is appointed by the Mayor and selected from the local citizenry. LAC's purpose is to "safeguard the city's historic and cultural heritage; foster civic pride in the beauty and noble accomplishments of the past..." Through the City's preservation program, the LAC and City staff provide assurance to district residents that work done in their neighborhoods will be compatible with the historic character and architectural styles. As part of this goal and per the Secretary of the Interior's Standards, replacing wood windows on buildings listed on the Local Historic Inventory with vinyl or vinyl-clad windows or other non-wood windows requires historic review and approval.

### **Landmarks Advisory Commission**

City of Albany  
333 Broadalbin St. SW  
Albany, OR 97321  
541-917-7550  
[www.cityofalbany.net](http://www.cityofalbany.net)

***WHY SAY  
"NO" TO  
VINYL  
WINDOWS?***

